

Fassadenschnitt

Ring House

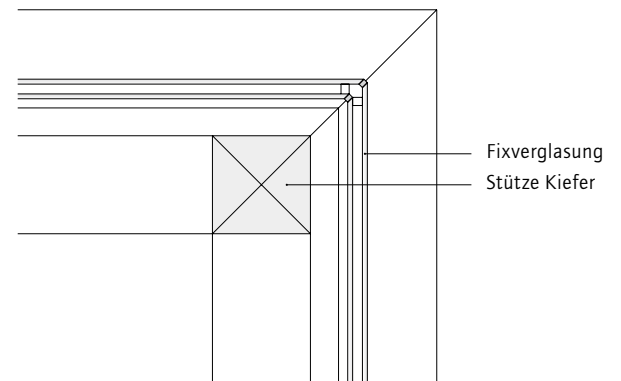

Horizontalschnitt Fassadenecke
Die rundumlaufenden Glasbänder werden an den Ecken geklebt, die Lastabtragung erfolgt über eine Klotzung unter dem Wetterschenkel.

Ort
Karuizawa (Japan)

Planung
Makoto Takei & Chie Nabeshima/TNA-architects
5-10-19-3F Yagummo Meguro-ku
Tokio, Japan 152-0023
T +81 (0)3/57011901
mail@tna-arch.com
www.tna-arch.com

Statik
Akira Suzuki/ASA, Tokio

Holzbau
Niitsu-gumi Co., Japan

Fertigstellung
2006